

# DTS-4O<sub>2</sub> Electrochemical Oxygen Gas Sensor

## Key Features:

High-sensitivity  
High-precision  
Linear output  
Unique leak-proof structure

## Typical Applications:

Method for industrial oxygen monitoring  
Environmental protection  
Oxygen monitoring in mine field  
Oxygen detection in storage area

## Product Introduction:

DTS-4O<sub>2</sub> oxygen sensor is a primary battery sensor, which uses the reduction reaction of oxygen on the working electrode and the corresponding reduction reaction of the cathode material to produce a current. The current generated is proportional to the oxygen concentration. The oxygen concentration can be determined by testing the current size.

## Technical Specifications:

Measuring Gas:	Oxygen (O <sub>2</sub> )
Measuring Range:	0-25%VOL
Maximum Overload:	30%VOL
Sensitivity:	3.8-5.7μA/vol%
Zero Drift:	< 0.2% vol
Resolution Ratio:	0.1%VOL
Response Time (T <sub>90</sub> ):	<10 Seconds
Output Linearity:	Linearity
<b>ENVIRONMENTAL:</b>	
Operating Temperature:	-40°C to +50°C
Operating Humidity:	15% -95% RH (no condensation)
Operating Pressure Range:	1 ± 0.1 standard atmospheric pressure
<b>LIFETIME:</b>	
Long Term Stability:	<5% Every year
Recommended Storage Temp:	0°C to 20°C in original packaging
Expected Operating Life:	For 24 months in the air
Storage Life:	The original package is 6 months
Standard Warranty	12 Months



## Product Dimensions:

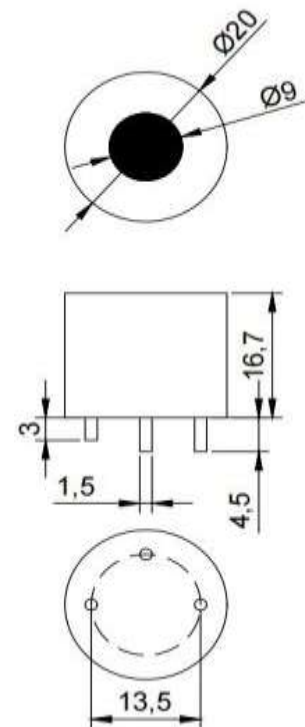

Figure 1: Unit: mm  
Unless otherwise specified,  
all tolerances are ±0.1mm.

Table 1: All performance data is based on conditions at 20°C, 50% RH, 1013mBar.

## Temperature Characteristic:

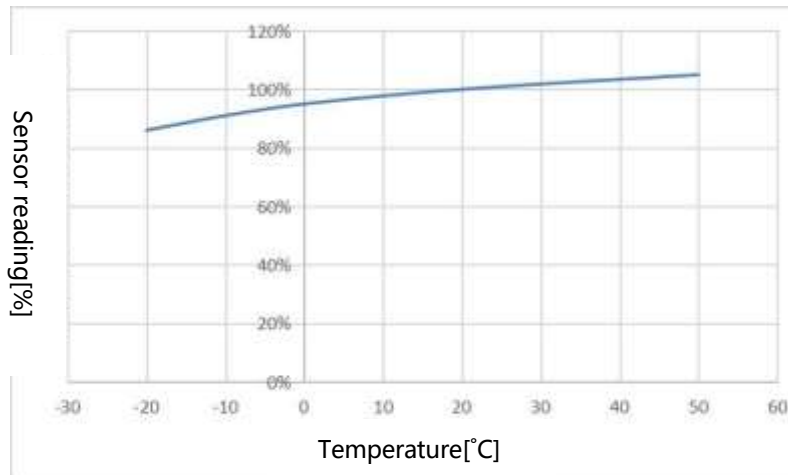

Figure 2: Temperature supplement compensation curve

## Long Term Stability:

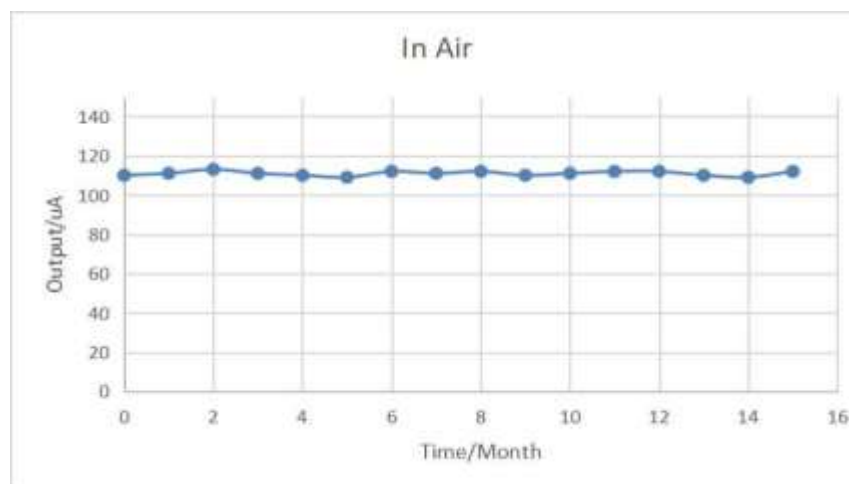

Figure 3: Long-term stability

Note: The above life test data is only the test results in the laboratory, and the actual service life should be determined according to the use of the field environment.

## Cross Sensitive Data:

Toxic gases do not have much cross-sensitive effect on DTS oxygen sensors at allowable concentrations. At high concentrations, high oxidation gases (such as percentage grade ozone, chlorine gas) can interfere with the diffusion of oxygen, but most ordinary gases do not.

**Important Note :**

1. The lead wire can be soldered during installation, and it is forbidden to contact the sensor during soldering.
2. The sensor should not be aged for less than 30min when the sensor is energized.
3. Avoid long-term exposure to organic volatile solvents and high concentration of other solvent vapors.
4. Store or use it in an appropriate environment and avoid the acid and alkali environment.
5. Avoid excessive impact or vibration on the sensor.

## DTS-4CO Electrochemical Carbon Monoxide Gas Sensor

### Key Features:

Linear Output  
 High Sensitivity  
 Anti-Interference  
 High-Accuracy  
 Unique Leak-Proof Structure

### Typical Applications:

Underground Pipe Gallery Gas Detection  
 Gas Detection In Underground Garage  
 Industrial Environment

### Product Introduction:

DTS-4CO, carbon monoxide sensor is a fixed potential electrolytic sensor. When the sensor senses the existence of carbon monoxide gas, the working electrode responds and produces an oxidation-reduction reaction. And the current is proportional to the concentration of carbon monoxide. The level of the concentration of carbon monoxide can be determined by testing the current.



### Technical Specifications:

Measuring gas:	Carbon monoxide (CO)
Measuring range:	0-1000ppm
Maximum Overload:	2000ppm
Output Signal:	60±15nA/ppm
Resolution Ratio:	< 1ppm
Response Time (T90):	<30 Seconds
Zero D r i f t:	< 3ppm
Output linearity:	Linear to 2,000 ppm
<b>ENVIRONMENTAL:</b>	
Operating Temperature:	-40°C to +50°C
Operating Humidity:	15% -90% RH (no-condensation)
Operating Pressure Range:	1 ± 0.1 standard atmospheric pressure
<b>LIFETIME:</b>	
Long Term Stability:	<2% Signal / month
Recommended Storage Temp:	0°C to 20°C in original packaging
Expected Operating Life:	For 24 months in the air
Storage Life:	The original package is 6 months
Standard Warranty	12 Months

### Product Dimensions:

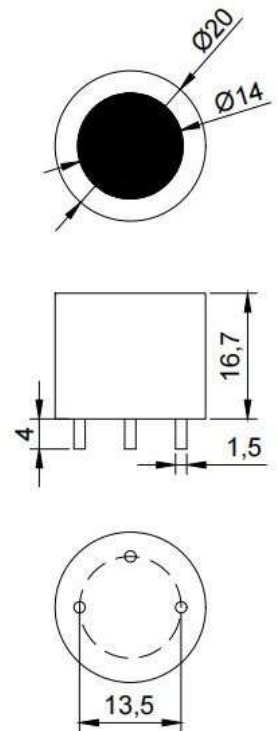

Figure 1: Unit: mm  
 Unless otherwise specified,  
 all tolerances are ±0.1mm.

Table 1:All performance data is based on conditions at 20°C, 50% RH, 1013mBar.

## Temperature Characteristic:

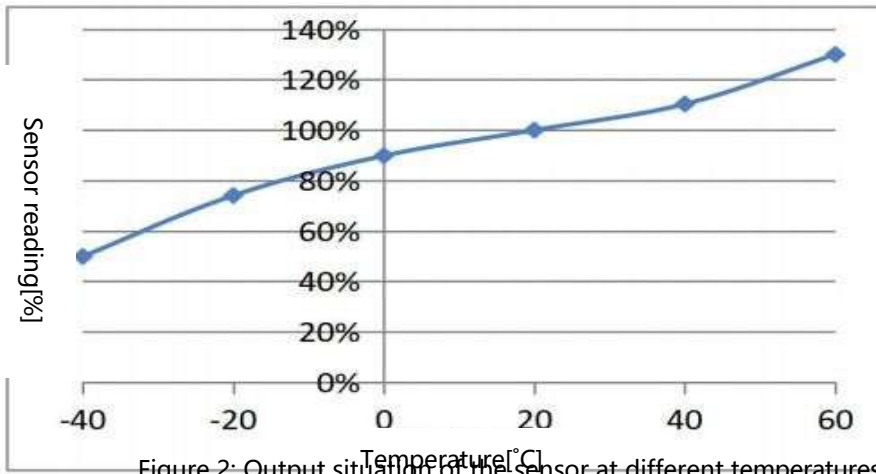

Figure 2: Output situation of the sensor at different temperatures

## Cross Interference Characteristics:

The typical cross-sensitivity characteristics of the sensor response to various interference gases / (25°C) are listed in the following table for reference.

Gas	Potency (ppm)	CO equivalent concentration (ppm)
Hepatic gas	20 PPM	0 PPM
Sulfur dioxide	10 PPM	0 PPM
Hydrogen	100 PPM	50PPM
Nitrogen dioxide	10PPM	-1.5 PPM
Alcohol	100 PPM	0 PPM
Ammonia	100 PPM	0 PPM

Table 2: Cross-interference characteristics

## Important Note :

1. The lead wire can be soldered during installation, and it is forbidden to contact the sensor during soldering.
2. The sensor should not be aged for less than 30min when the sensor is energized.
3. Avoid long-term exposure to organic volatile solvents and high concentration of other solvent vapors.
4. Store or use it in an appropriate environment and need to avoid the acid and alkali environment.
5. Avoid excessive impact or vibration on the sensor.

## DTS-4H<sub>2</sub>S Electrochemical Hydrogen Sulfide Gas Sensor

### Key Features:

High sensitivity  
High-precision  
Anti-interference  
The linear output  
Unique leak-proof structure

### Typical Applications:

Industrial leakage monitoring  
Environmental protection  
Underground pipe gallery

### Product Introduction:

DTS-4H<sub>2</sub>S hydrogen sulfide sensor is a fixed potential electrolytic sensor, when the sensor senses the existence of hydrogen sulfide gas, the working electrode responds and produces an oxidation-reduction reaction. And the current generated is proportional to the hydrogen sulfide concentration of hydrogen sulfide, through the test of the current you can determine the level of hydrogen sulfide concentration.

### Technical Specifications:

Measuring Gas:	Hydrogen Sulfide (H <sub>2</sub> S )
Measuring Range:	0-500ppm
Maximum Overload:	1000ppm
Output Signal:	0.65±0.15μ A/ppm
Resolution Ratio:	< 0.5ppm
Response Time (T90):	<30 Seconds
Zero Drift:	< 1ppm
Output Linearity:	Linearity
<b>ENVIRONMENTAL:</b>	
Operating Temperature:	-40°C to +50°C
Operating Humidity:	15% -90% RH (no-condensation)
Operating Pressure Range:	1 ± 0.1 standard atmospheric pressure
<b>LIFETIME:</b>	
Long Term Stability:	<2% Signal / month
Recommended Storage Temp:	0°C to 20°C in original packaging
Expected Operating Life:	For 24 months in the air
Storage Life:	The original package is 6 months
Standard Warranty	12 Months



### Product Dimensions:

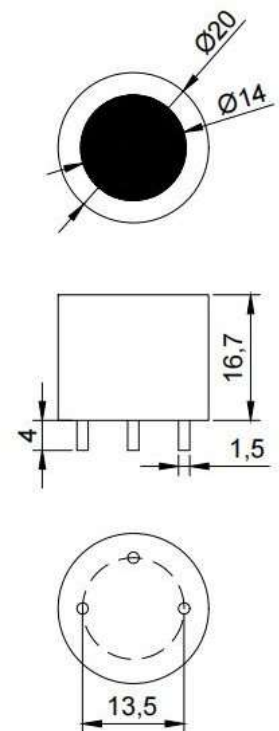

Figure 1: Unit: mm  
Unless otherwise specified,  
all tolerances are ±0.1mm.

Table 1: All performance data is based on conditions at 20°C, 50% RH, 1013mBar.

## Temperature Supplement Features:

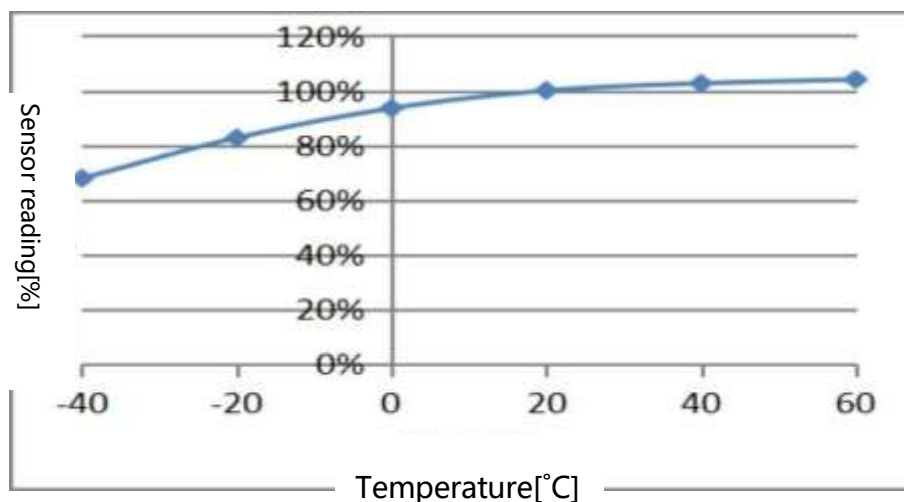

Figure 2: Temperature supplement compensation curve

## Cross Interference Characteristics:

The typical cross-sensitivity characteristics of the sensor response to various interference gases / (25°C) are listed in the following table for reference.

Gas	Potency (ppm)	Hydrogen Sulfide equivalent concentration (ppm)
Carbon monoxide	100	<0.5
Hydrogen	1000	<20
Ammonia	25	<0.3
Carbon dioxide	5000	0
Alcohol	100	<1

Table 2: Cross-interference characteristics

### Important Note :

1. The lead wire can be soldered during installation, and it is forbidden to contact the sensor during soldering.
2. The sensor should avoid long-term contact with paint, coatings and high concentration gas.
3. Avoid long-term exposure to organic volatile solvents and high concentration of other solvent vapors.
4. Store or use it in an appropriate environment and avoid the acid and alkali environment.
5. Avoid excessive impact or vibration on the sensor.

## DTS-4NH<sub>3</sub> Electrochemical Ammonia Gas Sensor

### Key Features:

High Sensitivity  
High-Precision  
Linear Output  
Anti-Interference  
Long-Life

### Application Areas:

Industrial Gas Leakage Monitoring  
Gas Monitoring In Animal Husbandry  
Gas Monitoring In Smart City  
Environmental Protection

### Product Introduction:

DTS-4 NH<sub>3</sub> ammonia sensor is a fixed potential electrolytic type sensor, when the sensor detects the presence of ammonia gas, the working electrode responds and produces an oxidation-reduction reaction. And the current is proportional to the concentration of the ammonia gas, the magnitude of current can determine the level of ammonia gas concentration.



### Performance Parameters:

Measuring Gas:	Ammonia (NH <sub>3</sub> )
Measuring Range:	0-100ppm
Extreme Overload:	200ppm
Output Signal:	0.1±0.04μA/ppm
Resolution Ratio:	< 0.5ppm
Response Time (T90):	<90 Seconds
Zero Current (Offset):	< 3ppm
Output Linearity:	Linearity
<b>ENVIRONMENTAL:</b>	
Operating Temperature:	-40°C to +50°C
Operating Humidity:	15% -90% RH (no-condensation)
Operating Pressure Range:	1 ± 0.1 standard atmospheric pressure
<b>LIFETIME:</b>	
Long Term Stability:	<2% Signal / month
Recommended Storage Temp:	0°C to 20°C in original packaging
Expected Operating Life:	For 24 months in the air
Storage Life:	The original package is 6 months
Standard Warranty	12 Months

### Product Dimensions:

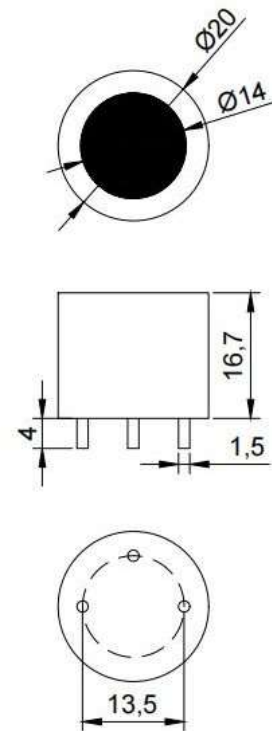

Figure 1: Unit: mm  
Unless otherwise specified,  
all tolerances are ±0.1mm.

Table 1: All performance data is based on conditions at 20°C, 50% RH, 1013mBar.



## Temperature Characteristic:

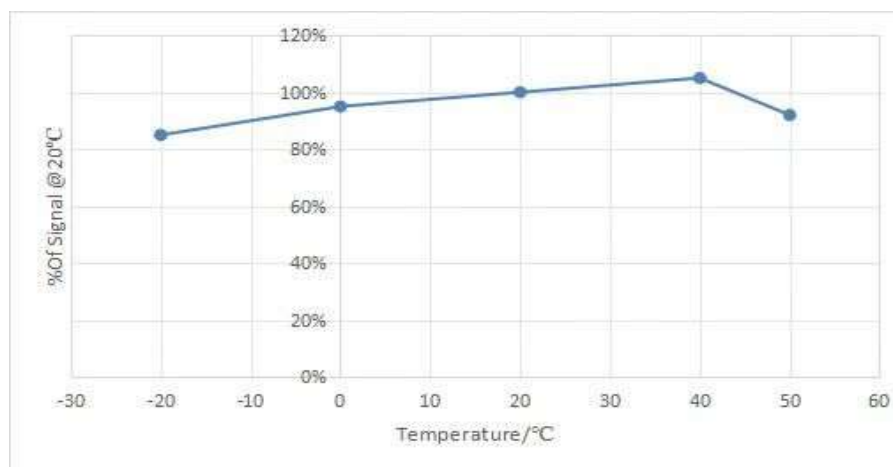

Figure 2: Output situation of the sensor at different temperatures

## Cross Interference Characteristics:

The typical cross-sensitivity characteristics of the sensor response to various interference gases / (25°C) are listed in the following table for reference.

Gas	Potency (ppm)	Ammonia Gas Equivalent Concentration (ppm)
Hepatic Gas	25	30
Hydrogen	100	0
Carbon Dioxide	5000	0
Carbon Monoxide	1000	0
Alcohol	100	<1

Table 2: Cross-interference characteristics

## Important Note :

1. The lead wire can be soldered during installation, and it is forbidden to contact the sensor during soldering.
2. The sensor should not be aged for less than 30min when the sensor is energized.
3. Avoid long-term exposure to organic volatile solvents and high concentration of other solvent vapors.
4. Store or use it in an appropriate environment and avoid the acid and alkali environment.
5. Avoid excessive impact or vibration on the sensor.

## DTS-4Cl<sub>2</sub> Electrochemical Chlorine Gas Sensor

### Key Features:

High Sensitivity  
High-Precision  
Anti-Interference  
Unique Leakage-Proof Structural

### Typical Applications:

Petrochemical Industry  
Industrial Production  
Environmental Protection  
Pharmaceutical Production

### Product Introduction:

DTS-4Cl<sub>2</sub> Chlorine sensor is a fixed potential electrolytic sensor, when the sensor senses the existence of chlorine gas, the working electrode responds and produces an oxidation-reduction reaction. And the current generated is proportional to the concentration of chlorine gas, by testing the current concentration the concentration of chlorine gas can be determined.



### Technical Specifications:

Measuring gas:	Chlorine (Cl <sub>2</sub> )
Measuring range:	0-10ppm
Maximum overload:	50ppm
Output signal:	-0.35±0.1μA/ppm
Resolution ratio:	0.05ppm
Response time (T90):	≤60 Seconds
Zero Current (Offset):	< 1ppm
Bias voltage:	0mV
<b>ENVIRONMENTAL:</b>	
Operating Temperature:	-40°C to +50°C
Operating Humidity:	15% -90% RH (no-condensation)
Operating Pressure Range:	1 ± 0.1 standard atmospheric pressure
<b>LIFETIME:</b>	
Long Term Stability:	<2% Signal / month
Recommended Storage Temp:	0°C to 20°C in original packaging
Expected Operating Life:	For 24 months in the air
Storage Life:	The original package is 6 months
Standard Warranty	12 Months

Table 1: All performance data is based on conditions at 20°C, 50% RH, 1013mBar.

### Product Dimensions:

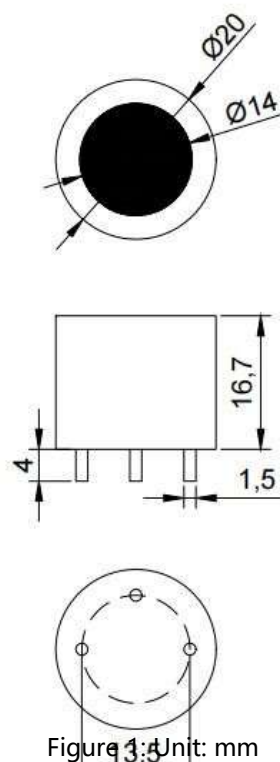

Figure 1: Unit: mm  
Unless otherwise specified, all tolerances are ±0.1mm.

## Temperature Supplement Features:

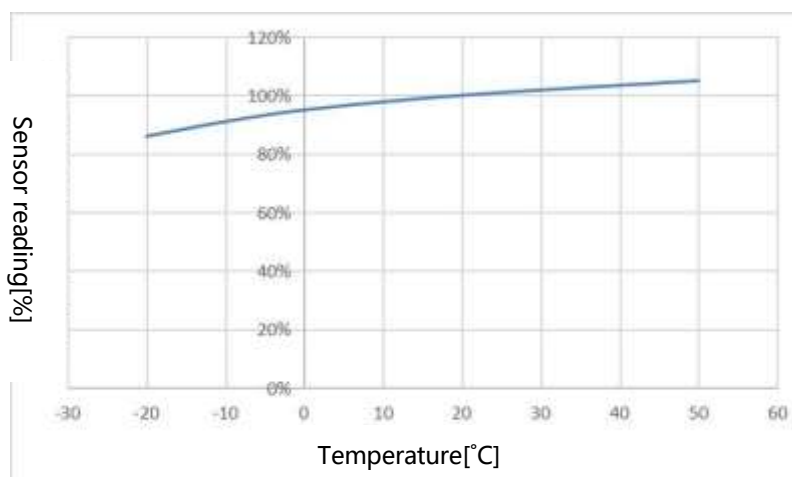

Figure 2: Temperature supplement compensation curve

## Cross Interference Characteristics:

The typical cross-sensitivity characteristics of the sensor response to various interference gases / (25°C) are listed in the following table for reference.

Gas	Potency (ppm)	Chlorine gas equivalent concentration (ppm)
Hepatic gas	10	-18
Sulfur dioxide	20	0
Nitrogen dioxide	10	8
Ammonia	10	0
Ozone	10	12
Hydrogen	100	0

Table 2: Cross-interference characteristics

## Important Note :

1. The lead wire can be soldered during installation, and it is forbidden to contact the sensor during soldering.
2. The sensor should avoid long-term contact with paint, coatings and high concentration gas.
3. It is prohibited to crush and damage the product in the process of use;
4. Never use the binder above or next to the sensor to avoid blocking the air inlet.
5. Avoid excessive impact or vibration on the sensor.

## DTS-4H2 Electrochemical Hydrogen Gas Sensor

### Key Features:

High sensitivity  
Linear output  
Anti-interference  
High-accuracy  
Unique leak-proof structure

### Typical Applications:

Chemical hydrogen  
Energy storage and hydrogen detection

### Product Introduction:

DTS-4H2 hydrogen sensor is a fixed potential electrolytic sensor. When the sensor senses the existence of hydrogen, the working electrode responds and produces an oxidation-reduction reaction. And the electrode is proportional to the concentration of hydrogen. The hydrogen concentration can be determined by testing the current.



### Technical Specifications:

Measuring Gas:	Hydrogen gas (H <sub>2</sub> )
Measuring Range:	0-1000ppm
Maximum Overload:	2000ppm
Output Signal:	30±15nA/ppm
Resolution Ratio:	< 5ppm
Response Time (T <sub>90</sub> ):	<60 Seconds
Zero Current (Offset):	< 10ppm
Output Linearity:	Linear to 2,000 ppm
<b>ENVIRONMENTAL:</b>	
Operating Temperature:	-40°C to +50°C
Operating Humidity:	15% -90% RH (no-condensation)
Operating Pressure Range:	1 ± 0.1 standard atmospheric pressure
<b>LIFETIME:</b>	
Long Term Stability:	<2% Signal / month
Recommended Storage Temp:	0°C to 20°C in original packaging
Expected Operating Life:	For 24 months in the air
Storage Life:	The original package is 6 months
Standard Warranty	12 Months

### Product Dimensions:

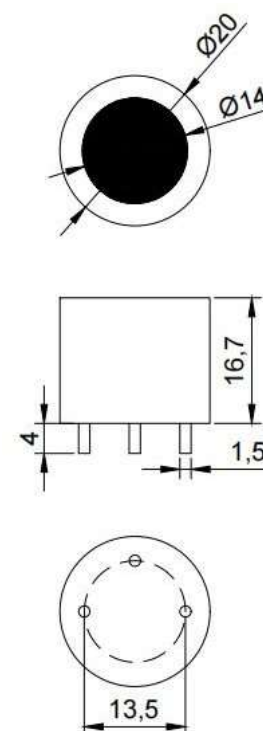

Figure 1: Unit: mm  
Unless otherwise specified, all tolerances are ±0.1mm.

Table 1: All performance data is based on conditions at 20°C, 50% RH, 1013mBar.

## Temperature Characteristic:

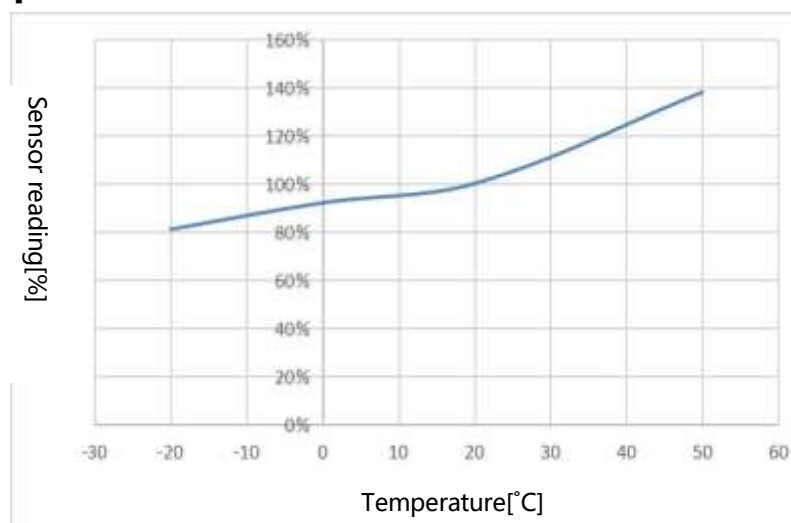

Figure 2: Output situation of the sensor at different temperatures

## Cross Interference Characteristics:

The typical cross-sensitivity characteristics of the sensor response to various interference gases / (25°C) are listed in the following table for reference.

gas	potency (ppm)	Hydrogen equivalent concentration (ppm)
hepatic gas	20 PPM	0 PPM
sulfur dioxide	10 PPM	0 PPM
carbon monoxide	50 PPM	100PPM
nitrogen dioxide	10PPM	-1.5 PPM
alcohol	100PPM	0 PPM
ethylene	100ppm	80ppm

Table 2: Cross-interference characteristics

## Important Note :

1. The lead wire can be soldered during installation, and it is forbidden to contact the sensor during soldering.
2. The sensor should not be aged for less than 30min when the sensor is energized.
3. Avoid long-term exposure to organic volatile solvents and high concentration of other solvent vapors.
4. Store or use it in an appropriate environment and avoid the acid and alkali environment.
5. Avoid excessive impact or vibration on the sensor.

## DTS-4O<sub>3</sub> Electrochemical Ozone Gas Sensor

### Key Features:

High Sensitivity  
High-Precision  
Anti-Interference  
Unique Leak-Proof Structure

### Typical Applications:

Environmental Protection Field  
Industrial Production  
Power Field

### Product Introduction:

DTS-4O<sub>3</sub>Ozone sensor is a fixed potential electrolytic sensor, when the sensor senses the existence of ozone gas, the working electrode responds and produces an oxidation-reduction reaction. And the magnitude of current is proportional to the ozone concentration, by testing the current size can determine the ozone concentration.



### Technical Specifications:

Measuring Gas:	Ozone (O <sub>3</sub> )
Measuring Range:	10ppm
Maximum Overload:	50ppm
Output Signal:	-0.45±0.15µA/ppm
Resolution Ratio:	0.05ppm
Response Time (T90):	≤60 Seconds
Zero Current (Offset):	< 0.2ppm
Bias Voltage:	0mV
<b>ENVIRONMENTAL:</b>	
Operating Temperature:	-40°C to +50°C
Operating Humidity:	15% -90% RH (no-condensation)
Operating Pressure Range:	1 ± 0.1 standard atmospheric pressure
<b>LIFETIME:</b>	
Long Term Stability:	<2% Signal / month
Recommended Storage Temp:	0°C to 20°C in original packaging
Expected Operating Life:	For 24 months in the air
Storage Life:	The original package is 6 months
Standard Warranty	12 Months

### Product Dimensions:

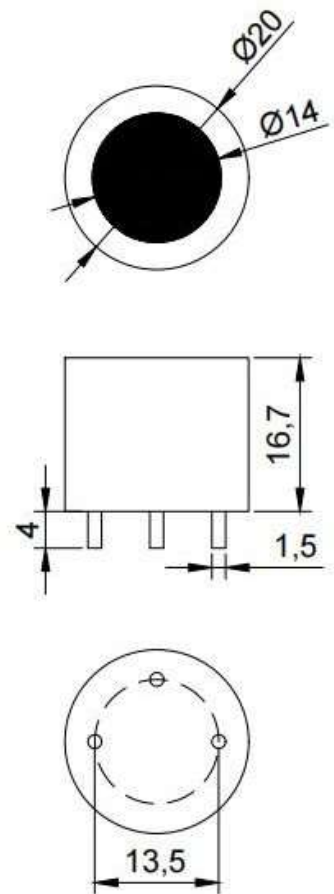

Figure 1: Unit: mm

Unless otherwise specified, all tolerances are ±0.1mm.

Table 1: All performance data is based on conditions at 20°C, 50% RH, 1013mBar.

## Temperature Supplement Features:

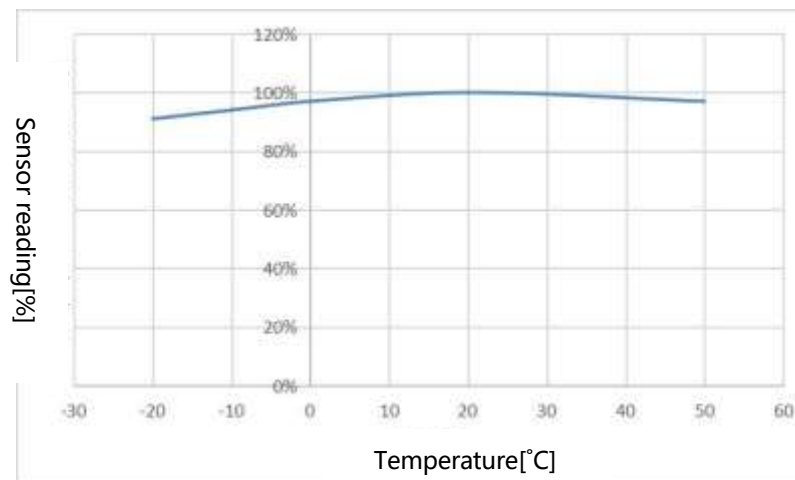

Figure 2: Temperature supplement compensation curve

## Cross Interference Characteristics:

The typical cross-sensitivity characteristics of the sensor response to various interference gases / (25°C) are listed in the following table for reference.

Gas	Potency (ppm)	Ozone-equivalent concentration (ppm)
Hepatic Gas	20	-8
Carbon Monoxide	100	0
Chlorine	10	9
Hydrogen	100	0
Sulfur Dioxide	20	<1
Nitrogen Dioxide	10	12

Table 2: Cross-interference characteristics

## Important Note :

- 1.The lead wire can be soldered during installation, and it is forbidden to contact the sensor during soldering.
- 2.The sensor should avoid long-term contact with paint, coatings and high concentration gas.
- 3.It is prohibited to crush and damage the product in the process of use;
- 4.Never use the binder above or next to the sensor to avoid blocking the air inlet.
- 5.Avoid excessive impact or vibration on the sensor.

## DTS-4NO<sub>2</sub> Electrochemical Nitrogen Dioxide Gas Sensor

### Key Features:

High Sensitivity  
High-Precision  
Anti-Interference  
Unique Leak-Proof Structure

### Typical Applications:

Petrochemical Industry  
Industrial Production  
Environmental Protection Field

### Product Introduction:

DTS-4NO<sub>2</sub> Nitrogen dioxide sensor is a fixed potential electrolytic sensor. When the sensor senses the existence of nitrogen dioxide gas, the working electrode responds and produces an oxidation-reduction reaction. And the current electrode is proportional to the concentration of nitrogen dioxide, and the concentration of the current can be determined by testing the concentration of nitrogen dioxide.



### Technical Specifications:

Measuring gas:	Nitrogen dioxide (NO <sub>2</sub> )
Measuring range:	20ppm
Maximum overload:	50ppm
Output signal:	-0.4±0.15μA/ppm
Resolution ratio:	0.1ppm
Response time (T90):	≤60 Seconds
Zero Current (Offset):	< 0.5ppm
Bias voltage:	0mV
<b>ENVIRONMENTAL:</b>	
Operating Temperature:	-40°C to +50°C
Operating Humidity:	15% -90% RH (no-condensation)
Operating Pressure Range:	1 ± 0.1 standard atmospheric pressure
<b>LIFETIME:</b>	
Long Term Stability:	<2% Signal / month
Recommended Storage Temp:	10°C to 30°C in original packaging
Expected Operating Life:	For 24 months in the air
Storage Life:	The original package is 6 months
Standard Warranty	12 Months

Table 1: All performance data is based on conditions at 20°C, 50% RH, 1013mBar.

### Product Dimensions:

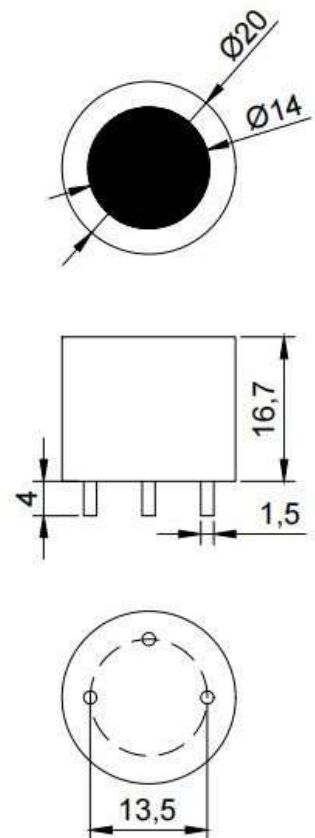

Figure 1: Unit: mm  
Unless otherwise specified,  
all tolerances are ±0.1mm.



## Temperature Supplement Features:

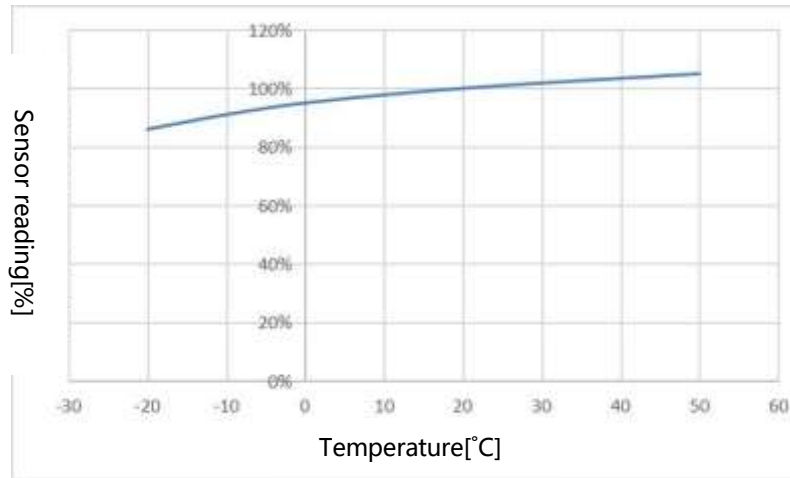

Figure 2: Temperature supplement compensation curve

## Cross Interference Characteristics:

The typical cross-sensitivity characteristics of the sensor response to various interference gases / (25°C) are listed in the following table for reference.

Gas	Potency (Ppm)	Nitrogen Dioxide Equivalent Concentration (Ppm)
Hepatic Gas	20	< 1
Carbon Monoxide	100	< 1
Chlorine	20	< 1
Ozone	10	< 2
Sulfur Dioxide	10	0
Nitric Oxide	100	0

Table 2: Cross-interference characteristics

## Important Note :

1. The lead wire can be soldered during installation, and it is forbidden to contact the sensor during soldering.
2. The sensor should avoid long-term contact with paint, coatings and high concentration gas.
3. It is prohibited to crush and damage the product in the process of use;
4. Never use the binder above or next to the sensor to avoid blocking the air inlet.
5. Avoid excessive impact or vibration on the sensor.

## DTS-4HCL Electrochemical Hydrogen Chloride Gas Sensor

### Key Features:

High Sensitivity  
High-Precision  
Anti-Interference  
Unique Leakage-Proof Structural

### Typical Applications:

Petrochemical Industry  
Industrial Production  
Environmental Protection  
Pharmaceutical Production

### Product Introduction:

DTS-4HCL Hydrogen chloride sensor is a fixed potential electrolytic sensor, when the sensor senses the existence of hydrogen chloride gas, the working electrode responds and produces an oxidation-reduction reaction. And the current generated is proportional to the concentration of hydrogen chloride gas, by testing the current concentration the concentration of hydrogen chloride gas can be determined.



### Technical Specifications:

Measuring gas:	Hydrogen chloride (HCL)
Measuring range:	0-10ppm
Maximum overload:	50ppm
Output signal:	0.25±0.1µA/ppm
Resolution ratio:	<0.5ppm
Response time (T90):	≤60 Seconds
Zero Current (Offset):	< 5ppm
Bias voltage:	+200mV
<b>ENVIRONMENTAL:</b>	
Operating Temperature:	-40°C to +50°C
Operating Humidity:	15% -90% RH (no-condensation)
Operating Pressure Range:	1 ± 0.1 standard atmospheric pressure
<b>LIFETIME:</b>	
Long Term Stability:	<2% Signal / month
Recommended Storage Temp:	0°C to 20°C in original packaging
Expected Operating Life:	For 24 months in the air
Storage Life:	The original package is 6 months
Standard Warranty	12 Months

### Product Dimensions:

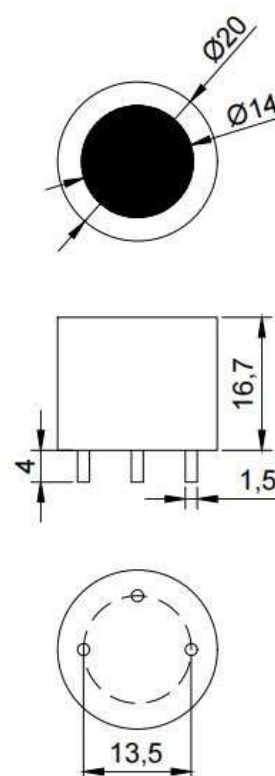

Figure 1: Unit: mm  
Unless otherwise specified,  
all tolerances are ±0.1mm.

Table 1: All performance data is based on conditions at 20°C, 50% RH, 1013mBar.

## Temperature Supplement Features:

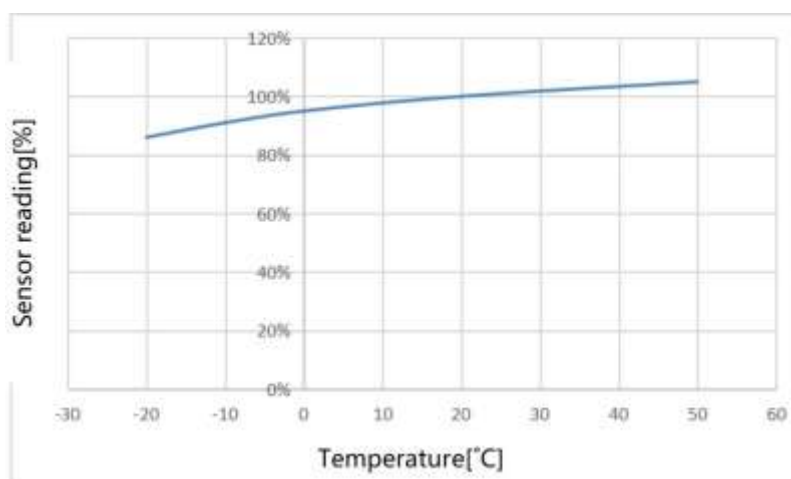

Figure 2: Temperature supplement compensation curve

## Cross Interference Characteristics:

The typical cross-sensitivity characteristics of the sensor response to various interference gases / (25°C) are listed in the following table for reference.

Gas	Potency (ppm)	Chlorine gas equivalent concentration (ppm)
Combine Dioxide	100	0
Hydrogen	100	0
Chlorine	10	-3
Nitrogen Dioxide	10	-1
Hydrogen Sulfide	30	100
Nitrogen	100	0

Table 2: Cross-interference characteristics

## Important Note :

1. The lead wire can be soldered during installation, and it is forbidden to contact the sensor during soldering.
2. The sensor should not be aged for less than 30min when the sensor is energized.
3. Avoid long-term exposure to organic volatile solvents and high concentration of other solvent vapors.
4. Store or use it in an appropriate environment and need to avoid the acid and alkali environment.
5. Avoid excessive impact or vibration on the sensor.

## DTS-4SO<sub>2</sub> Electrochemical Sulfur Dioxide Gas Sensor

### Key Features:

High Sensitivity  
High-Precision  
Anti-Interference  
Unique Leak-Proof Structure

### Typical Applications:

Environmental Protection Field  
Industrial Production

### Product Introduction:

DTS-4SO<sub>2</sub> Sulfur dioxide sensor is a fixed potential electrolytic sensor, when the sensor senses the existence of sulfur dioxide gas, the working electrode and the sulfur dioxide response to the electrode, the current generated is proportional to the concentration of sulfur dioxide, through the test of the current can determine the concentration of sulfur dioxide.



### Technical Specifications:

Measuring gas:	Sulfur dioxide (SO <sub>2</sub> )
Measuring range:	20ppm
Maximum overload:	50ppm
Output signal:	0.25±0.1μA/ppm
Resolution ratio:	0.1ppm
Response time (T90):	≤30 Seconds
Zero Current (Offset):	< 0.5ppm
Bias voltage:	0mV
<b>ENVIRONMENTAL:</b>	
Operating Temperature:	-40°C to +50°C
Operating Humidity:	15% -90% RH (no-condensation)
Operating Pressure Range:	1 ± 0.1 standard atmospheric pressure
<b>LIFETIME:</b>	
Long Term Stability:	<2% Signal / month
Recommended Storage Temp:	0°C to 20°C in original packaging
Expected Operating Life:	For 24 months in the air
Storage Life:	The original package is 6 months
Standard Warranty	12 Months

### Product Dimensions:

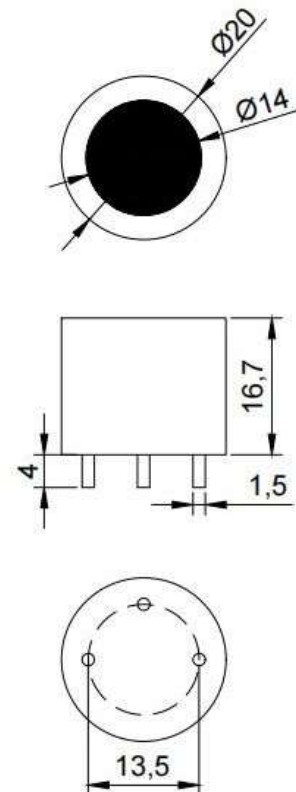

Figure 1: Unit: mm

Unless otherwise specified, all tolerances are ±0.1mm.

Table 1: All performance data is based on conditions at 20°C, 50% RH, 1013mBar.

## Temperature Supplement Features:

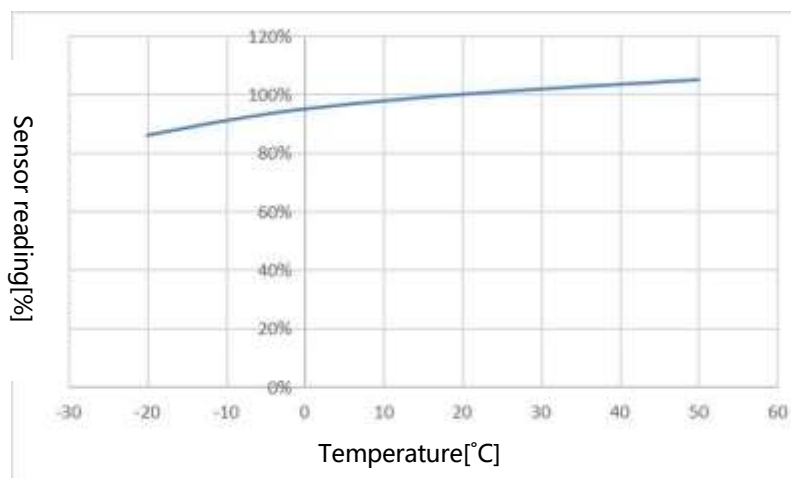

Figure 2: Temperature supplement compensation curve

## Cross Interference Characteristics:

The typical cross-sensitivity characteristics of the sensor response to various interference gases / (25°C) are listed in the following table for reference.

Gas	Potency (ppm)	Ozone-equivalent concentration (ppm)
Hepatic gas	20	0.1
Carbon monoxide	100	0.1
Chlorine	5	-1.5
Hydrogen	100	0
Ammonia	10	0
Nitrogen dioxide	10	-15

Table 2: Cross-interference characteristics

## Important Note :

1. The lead wire can be soldered during installation, and it is forbidden to contact the sensor during soldering.
2. The sensor should avoid long-term contact with paint, coatings and high concentration gas.
3. It is prohibited to crush and damage the product in the process of use;
4. Never use the binder above or next to the sensor to avoid blocking the air inlet.
5. Avoid excessive impact or vibration on the sensor.

\

## DTS-4PH3 Electrochemical Phosphine Gas Sensor

### Features:

High Sensitivity  
High-Precision  
Linear Output  
Anti-Interference  
Unique Leak-Proof Structure

### Typical Applications:

Industrial Phosphine Leakage Monitoring  
Granary Storage

### Product Introduction:

DTS-4PH3 phosphine, the sensor is a fixed potential electrolytic sensor, when the sensor senses the existence of phosphine gas, the working electrode and the REDOX reaction responding to the electrode, the current generated is proportional to the concentration of phosphine, through the test of the current can determine the concentration of phosphine.



### Technical Specifications:

Measuring Gas:	Phosphine hydrogen (PH <sub>3</sub> )
Measuring Range:	0-20ppm
Maximum Overload:	100ppm
Output Signal:	1.4±0.6μA/ppm
Resolution Ratio:	< 0.05ppm
Response Time (T <sub>90</sub> ):	<30 Seconds
Zero Current (Offset):	< 1ppm
Output Linearity:	Linearity
<b>ENVIRONMENTAL:</b>	
Operating Temperature:	-40°C to +50°C
Operating Humidity:	15% -90% RH (no-condensation)
Operating Pressure Range:	1 ± 0.1 standard atmospheric pressure
<b>LIFETIME:</b>	
Long Term Stability:	<2% Signal / month
Recommended Storage Temp:	0°C to 20°C in original packaging
Expected Operating Life:	For 24 months in the air
Storage Life:	The original package is 6 months
Standard Warranty	12 Months

Table 1: All performance data is based on conditions at 20°C, 50% RH, 1013mBar.

### Product Dimensions:

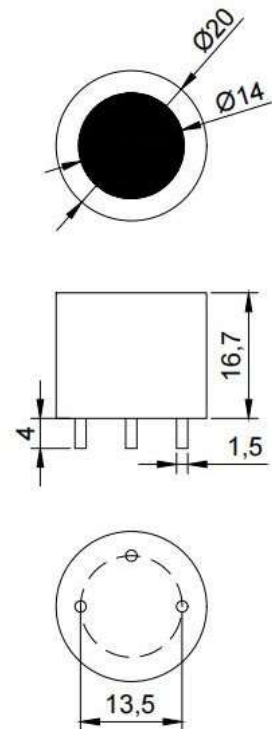

Figure 1: Unit: mm  
Unless otherwise specified,  
all tolerances are ±0.1mm.

## Temperature Supplement Features:

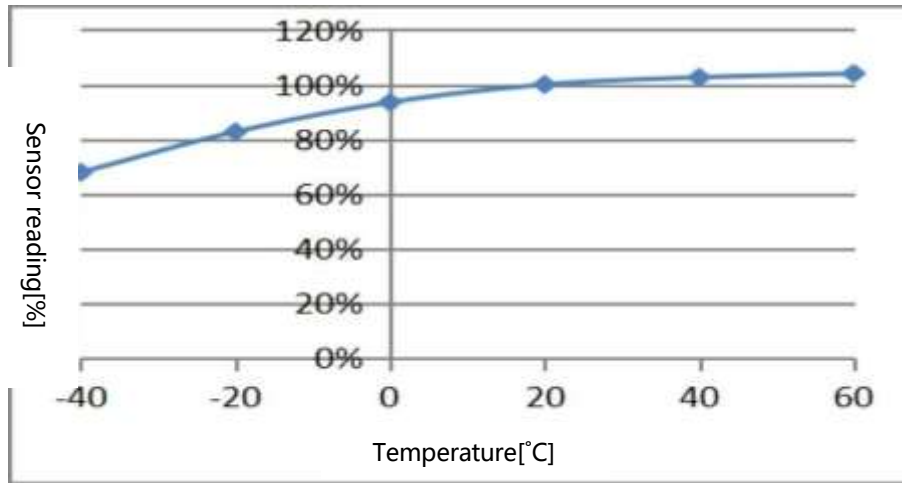

Figure 2: Temperature supplement compensation curve

## Cross Interference Characteristics:

The typical cross-sensitivity characteristics of the sensor response to various interference gases / (25°C) are listed in the following table for reference.

Gas	Potency (ppm)	Phosphorine Equivalent Concentration (ppm)
Hepatic Gas	15	12
Hydrogen	1000	0
Ammonia	50	0
Sulfur Dioxide	20	6
Ethylene	100	0
Carbon Monoxide	1000	0

Table 2: Cross-interference characteristics

## Important Note :

1. The lead wire can be soldered during installation, and it is forbidden to contact the sensor during soldering.
2. The sensor should not be aged for less than 30min when the sensor is energized.
3. Avoid long-term exposure to organic volatile solvents and high concentration of other solvent vapors.
4. Store or use it in an appropriate environment and avoid the acid and alkali environment.
5. Avoid excessive impact or vibration on the sensor.

## DTS-4C<sub>7</sub>H<sub>8</sub> Electrochemical Toluene Gas Sensor

### Key Features:

High Sensitivity  
High-precision  
Anti-interference  
Unique Leakage-proof Structural

### Typical Applications:

Petrochemical Industry  
Industrial Production  
Smelting and Forging  
Pharmaceutical Industry

### Product Introduction:

DTS-4C<sub>7</sub>H<sub>8</sub>Toluene sensor is a fixed potential electrolytic sensor, when the sensor senses the existence of toluene gas, the working electrode and the REDOX reaction responding to the electrode, the current generated is proportional to the concentration of toluene, the concentration of toluene can be determined by testing the current size of toluene.



### Technical Specifications:

Measuring Gas:	Methylbenzene (C <sub>7</sub> H <sub>8</sub> )
Measuring Range:	0-100ppm
Maximum Overload:	200ppm
Output Signal:	30±10nA/ppm
Resolution Ratio:	1.5ppm
Response Time (T90):	≤120 Seconds
Zero Current (Offset):	< 10ppm
Bias Voltage:	+300mV
<b>ENVIRONMENTAL:</b>	
Operating Temperature:	-40~+50°C
Operating Humidity:	15% -90% RH (no condensation)
Operating Pressure Range:	1 ± 0.1 standard atmospheric pressure
<b>LIFETIME:</b>	
long Term Stability:	<2% Signal / month
Recommended Storage Temp:	0°C to 20°C in original packaging
Expected Operating Life:	For 24 months in the air
Storage Life:	The original package is 6 months
Standard Warranty	12 Months

### Product Dimensions:

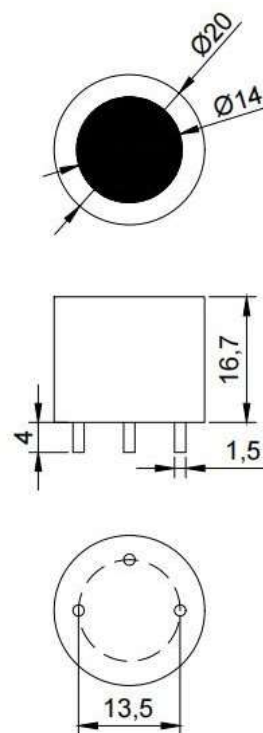

Figure 1: Unit: mm  
Unless otherwise specified,  
all tolerances are ±0.1mm.

Table 1: All performance data is based on conditions at 20°C, 50% RH, 1013mBar.



## Temperature Supplement Features:

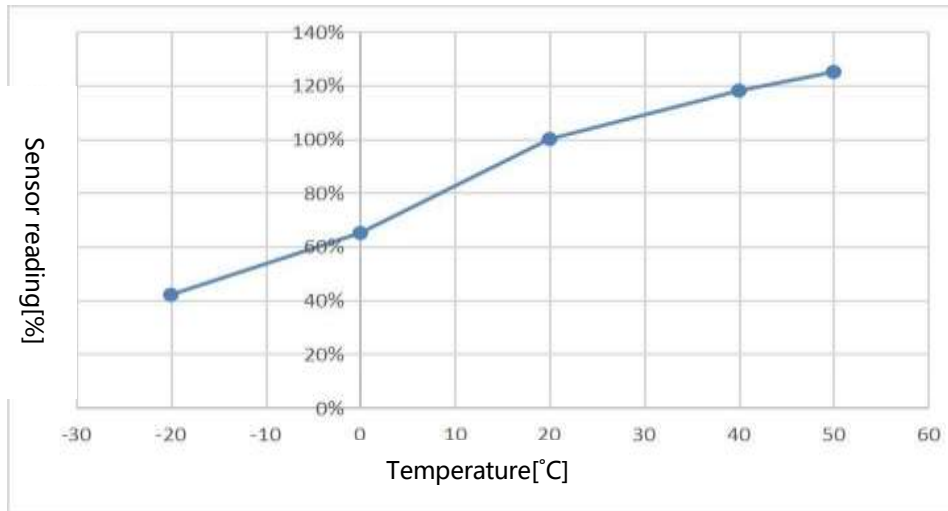

Figure 2: Temperature supplement compensation curve

## Cross Interference Characteristics:

The typical cross-sensitivity characteristics of the sensor response to various interference gases / (25°C) are listed in the following table for reference.

Gas	Potency (ppm)	Toluene equivalent Concentration (ppm)
Vinyl Chloride	100	180
Ethylene Oxide	10	30
Diethyl Ether	100	70
Xylene	100	140
Carbon Monoxide	200	150
Hydrogen Sulfide	100	300

Table 2: Cross-interference characteristics

## Important Note :

- 1.The lead wire can be soldered during installation, and it is forbidden to contact the sensor during soldering.
- 2.The sensor should avoid long-term contact with paint, coatings and high concentration gas.
- 3.It is prohibited to crush and damage the product in the process of use;
- 4.Never use the binder above or next to the sensor to avoid blocking the air inlet;
- 5.Avoid excessive impact or vibration on the sensor;

## DTS-4CH<sub>2</sub>O Electrochemical Formaldehyde Gas Sensor

### Key Features:

High Sensitivity  
High-precision  
Anti-interference  
Unique leak-proof Structure

### Typical Applications:

Petrochemical Industry  
Industrial Production  
Environmental Protection

### Product Introduction:

DTS-4CH<sub>2</sub>O formaldehyde sensor is a fixed potential electrolytic sensor. When the sensor senses the existence of formaldehyde gas, the working electrode responds and produces an oxidation-reduction reaction. And the electrode are proportional to the formaldehyde concentration, and the current concentration can be determined by testing the formaldehyde concentration.



### Technical Specifications:

Measuring Gas:	Formaldehyde (CH <sub>2</sub> O )
Measuring Range:	100ppm
Maximum Overload:	200ppm
Output Signal:	0.5±0.15μA/ppm
Resolution Ratio:	0.5ppm
Response Time (T90):	≤90 Seconds
Zero Current (Offset):	< 1ppm
Bias Voltage:	0mV
<b>ENVIRONMENTAL:</b>	
Operating Temperature:	-40°C to +50°C
Operating Humidity:	15% -90% RH (no-condensation)
Operating Pressure Range:	1 ± 0.1 standard atmospheric pressure
<b>LIFETIME:</b>	
Long Term Stability:	<2% Signal / month
Recommended Storage Temp:	0°C to 20°C in original packaging
Expected Operating Life:	For 24 months in the air
Storage Life:	The original package is 6 months
Standard Warranty	12 Months

### Product Dimensions:

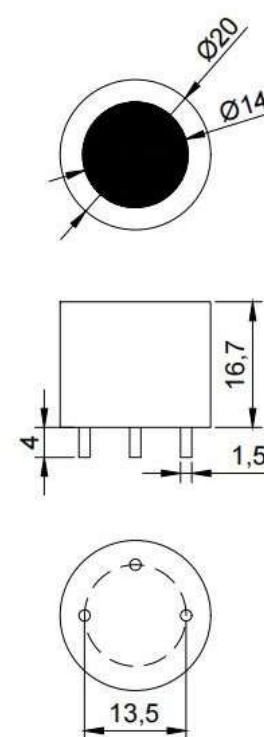

Figure 1: Unit: mm  
Unless otherwise specified, all tolerances are ±0.1mm.

Table 1: All performance data is based on conditions at 20°C, 50% RH, 1013mBar.

## Temperature Supplement Features:

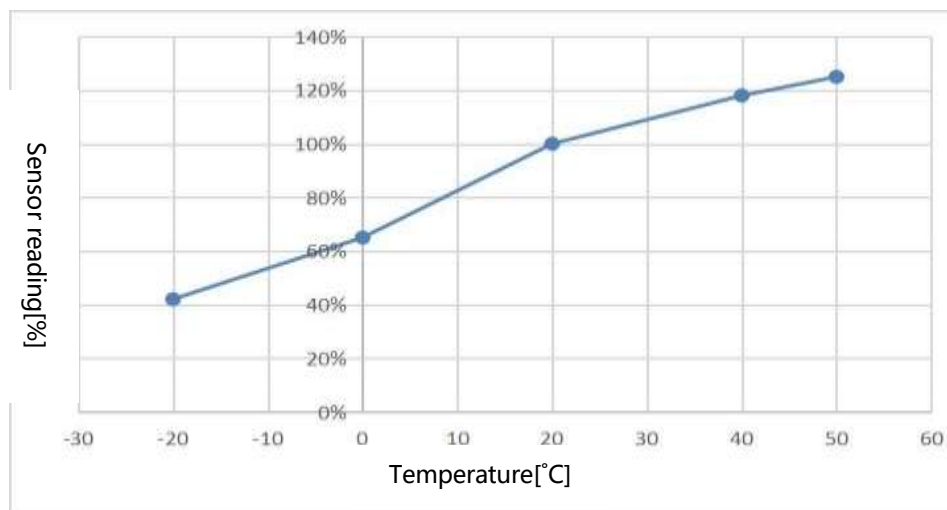

Figure 2: Temperature supplement compensation curve

## Cross Interference Characteristics:

The typical cross-sensitivity characteristics of the sensor response to various interference gases / (25°C) are listed in the following table for reference.

Gas	Potency (ppm)	Formaldehyde Equivalent Concentration (ppm)
Carbon Monoxide	50	5
Alcohol	300	20
Epoxyethane	10	1
Methylbenzene	50	3
Dimethylbenzene	50	5
Hepatic Gas	50	7
Sulfur Dioxide	20	1
Chlorethylene	100	10
Chloroform	50	1

Table 2: Cross-interference characteristics

## Important Note :

1. The lead wire can be soldered during installation, and it is forbidden to contact the sensor during soldering.
2. The sensor to avoid long-term contact with paint, coatings and high concentration gas.
3. It is prohibited to crush and damage the product in the process of use.
4. Do not use the binder above or beside the sensor to avoid blocking the air inlet.
5. Avoid excessive impact or vibration on the sensor.

## DTS-4 ETO Electrochemical Ethylene Oxide Gas Sensor

### Key Features:

High Sensitivity  
High-Precision  
Anti-Interference  
Unique Leak-Proof Structure

### Typical Applications:

Petrochemical Industry  
Industrial Production  
Environmental Protection  
Medical Production

### Product Introduction:

DTS-4 ETO ethylene Oxide sensor is a fixed potential electrolytic sensor. When the sensor senses the existence of ethylene oxide gas, the working electrode responds and produces an oxidation-reduction reaction. And the electrode are proportional to the concentration of ethylene oxide. The level of the concentration of ethylene oxide can be determined by testing the current.

### Technical Specifications:

Measuring Gas:	Ethylene oxide (ETO)
Measuring Range:	100ppm
Maximum Overload:	500ppm
Output Signal:	$0.20 \pm 0.12 \mu\text{A/ppm}$
Resolution Ratio:	1ppm
Response Time (T90):	$\leq 120$ Seconds
Zero Current (Offset):	$< 10$ ppm
Bias Voltage:	+300mV
<b>ENVIRONMENTAL:</b>	
Operating Temperature:	-40°C to +50°C
Operating Humidity:	15% -90% RH (no-condensation)
Operating Pressure Range:	$1 \pm 0.1$ standard atmospheric pressure
<b>LIFETIME:</b>	
Long Term Stability:	$< 2\%$ Signal / month
Recommended Storage Temp:	0°C to 20°C in original packaging
Expected Operating Life:	For 24 months in the air
Storage Life:	The original package is 6 months
Standard Warranty	12 Months



### Product Dimensions:

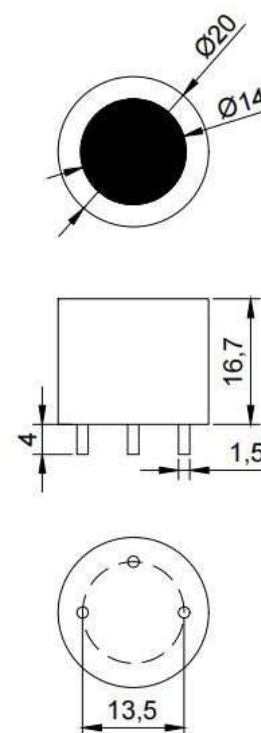

Figure 1: Unit: mm  
Unless otherwise specified,  
all tolerances are  $\pm 0.1$ mm.

Table 1: All performance data is based on conditions  $_1$  at 20°C, 50% RH, 1013mBar.

## Temperature Supplement Features:

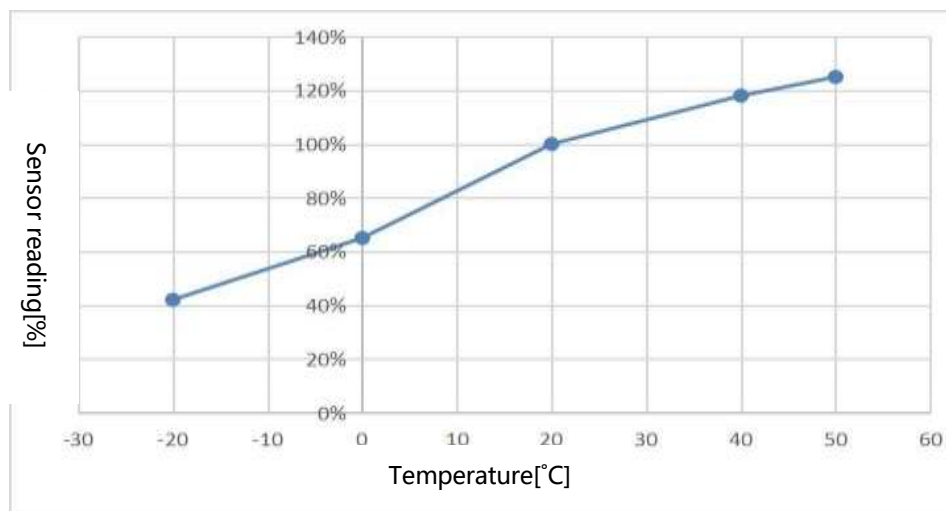

Figure 2: Temperature supplement compensation curve

## Cross Interference Characteristics:

The typical cross-sensitivity characteristics of the sensor response to various interference gases / (25°C) are listed in the following table for reference.

Gas	Potency (ppm)	Ethylene oxide equivalent concentration (ppm)
Isobutene	50	35
Carbon monoxide	30	15
Ethyl Alcohol	100	50
Ethylene	50	40
Formic acid	100	25
Methylbenzene	50	20
Chlorethylene	100	70
Dimethylbenzene	50	27
Chloroform	50	10

Table 2: Cross-interference characteristics

**Important Note :**

- 1.The lead wire can be soldered during installation, and it is forbidden to contact the sensor during soldering.
- 2.The sensor to avoid long-term contact with paint, coatings and high concentration gas.
- 3.It is prohibited to crush and damage the product during the process of use.
- 4.Do not use the binder above or beside the sensor to avoid blocking the air inlet.
- 5.Avoid excessive impact or vibration on the sensor.

## DTS-4HF Electrochemistry Hydrogen Fluoride Gas Sensor

### Key Features:

High Sensitivity  
High Precision  
Linear Output  
Anti-Interference  
Unique Leak-Proof Structure

### Typical Applications:

Industrial Gas Leakage  
Environmental Gas Detection

### Product Introduction:

DTS-4HF hydrogen fluoride sensor is a fixed potential electrolytic sensor, when the sensor senses the existence of hydrogen fluoride gas, the working electrode responds and produces an oxidation-reduction reaction. And the current generated is proportional to the concentration of hydrogen fluoride, the concentration of hydrogen fluoride can be determined through the test of the current .



### Technical Specifications:

Measuring Gas:	Hydrogen fluoride (HF)
Measuring Range:	0-10ppm
Maximum Overload:	50ppm
Output Signal:	-0.2±0.1μA/ppm
Resolution Ratio:	0.2ppm
Response Time (T90):	≤120 Seconds
Zero Current (Offset):	< 2ppm
Output Linearity:	Linearity
<b>ENVIRONMENTAL:</b>	
Operating Temperature:	-40°C to +50°C
Operating Humidity:	15% -90% RH (no-condensation)
Operating Pressure Range:	1 ± 0.1 standard atmospheric pressure
<b>LIFETIME:</b>	
Long Term Stability:	<2% Signal / month
Recommended Storage Temp:	0°C to 20°C in original packaging
Expected Operating Life:	For 24 months in the air
Storage Life:	The original package is 6 months
Standard Warranty	12 Months

### Product Dimensions:

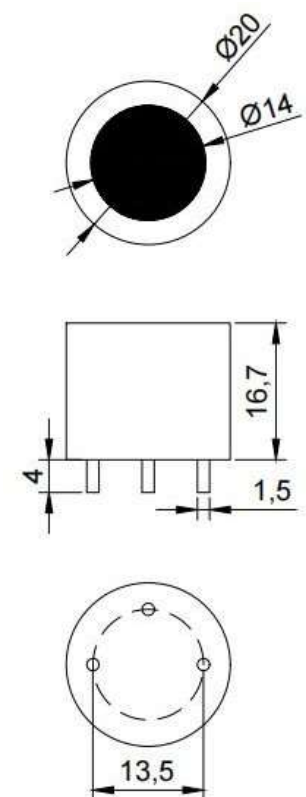

Figure 1: Unit: mm  
Unless otherwise specified,  
all tolerances are ±0.1mm.

Table 1: All performance data is based on conditions at 20°C, 50% RH, 1013mBar.

## Temperature Supplement Features:

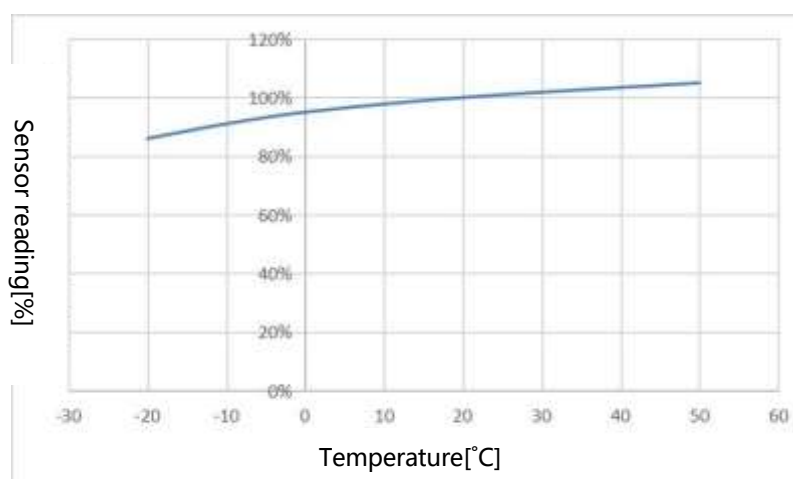

Figure 2: Temperature supplement compensation curve

## Cross Interference Characteristics:

The typical cross-sensitivity characteristics of the sensor response to various interference gases / (25°C) are listed in the following table for reference.

Gas	Potency (ppm)	Hydrogen fluoride equivalent concentration (ppm)
Carbon monoxide	100	0
Hydrogen	100	0
Nitric oxide	100	0
Nitrogen dioxide	5	7
Hepatic gas	20	-10
Sulfur dioxide	20	-0.3

Table 2: Cross-interference characteristics

## Important Note :

1. The lead wire can be soldered during installation, and it is forbidden to contact the sensor during soldering.
2. The sensor should not be aged for less than 30min when the sensor is energized.
3. Avoid long-term exposure to organic volatile solvents and high concentration of other solvent vapors.
4. Store or use it in an appropriate environment and avoid the acid and alkali environment.
5. Avoid excessive impact or vibration on the sensor.



## DTS-4HCN Electrochemical Hydrogen Cyanide Gas Sensor

### Key Features:

High sensitivity  
High-accuracy  
Linear output  
Anti-interference  
Unique leak-proof structure

### Typical Applications:

Industrial hydrogen cyanide leakage monitoring

### Product Introduction:

DTS-4HCN hydrogen cyanide sensor is a fixed potential electrolytic sensor, when the sensor detecting the existence of hydrogen cyanide gas, the working electrode responds and produces an oxidation-reduction reaction. And the current generated is proportional to the concentration of hydrogen cyanide, the concentration of hydrogen cyanide can be determined through the test of the current.



### Technical Specifications:

Measuring Gas:	Hydrogen cyanide (HCN)
Measuring Range:	0-10ppm
Maximum Overload:	50ppm
Output Signal:	0.1±0.02μA/ppm
Resolution Ratio:	< 0.1ppm
Response Time (T90):	<90 Seconds
Zero Current (Offset):	< 1ppm
Output Linearity:	Linearity
<b>ENVIRONMENTAL:</b>	
Operating Temperature:	-40—+50°C
Operating Humidity:	15% -90% RH (no-condensation)
Operating Pressure Range:	1 ± 0.1 standard atmospheric pressure
<b>LIFETIME:</b>	
Long Term Stability:	<2% Signal value / month
Recommended Storage Temp:	0°C to 20°C in original packaging
Expected Operating Life:	For 24 months in the air
Storage Life:	The original package is 6 months
Standard Warranty:	12 Months

Table 1: All performance data is based on conditions at 20°C, 50% RH, 1013mBar.

### Product Dimensions:

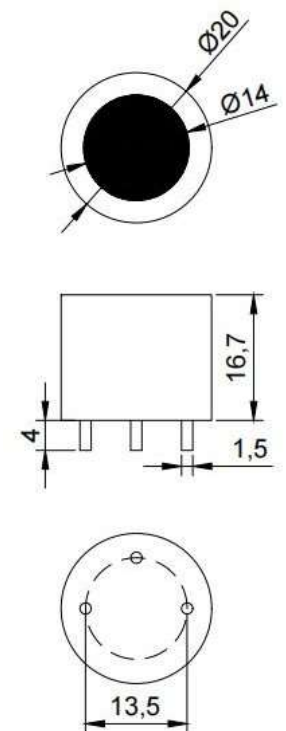

Figure 1: Unit: mm  
Unless otherwise specified,  
all tolerances are ±0.1mm.

## Temperature Supplement Features:

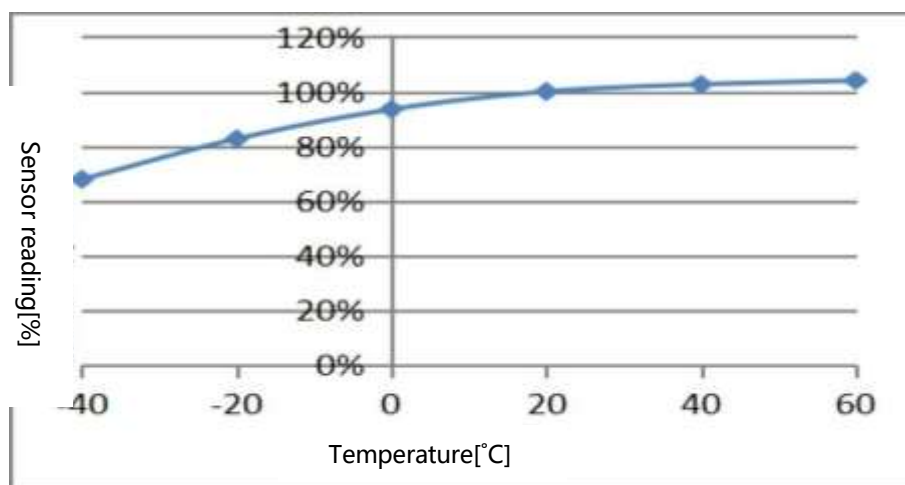

Figure 2: Temperature supplement compensation curve

## Cross-interference Characteristics:

The typical cross-sensitivity characteristics of the sensor response to various interference gases / (25°C) are listed in the following table for reference.

Gas	Potency (ppm)	Hydrogen cyanide equivalent concentration (ppm)
Hepatic gas	5	15.1
Nitrogen dioxide	5	-9.6
Sulfur dioxide	5	18.2
Ethylene	100	0
Carbon monoxide	500	0

Table 2: Cross-interference characteristics

## Important Note :

1. The lead wire can be soldered during installation, and it is forbidden to contact the sensor during soldering.
2. The sensor should not be aged for less than 30min when the sensor is energized.
3. Avoid long-term exposure to organic volatile solvents and high concentration of other solvent vapors.
4. Store or use it in an appropriate environment and avoid the acid and alkali environment.
5. Avoid excessive impact or vibration on the sensor.