



Recorder



Flow



Pressure



Temp



Analyzer



Level

Datasheet

Universal Controller

AI-MA-U2

Datasheet

Universal Controller AI-MA-U2

This product is a general-purpose controller for water quality, suitable for use with various water quality series digital sensors of our company. It is used to monitor water quality parameters including pH, ORP, conductivity, dissolved oxygen, turbidity, MLSS, inductive conductivity, free chlorine, ammonium, nitrate, COD and other water quality parameters. Through RS485 or current transmission output to the monitoring room for record keeping.

Applications

- pH/ORP sensor
- Conductivity sensor
- Inductive conductivity sensor
- Dissolved oxygen sensor
- Turbidity/MLSS sensor
- Chlorine sensor
- Ammonium sensor
- Nitrate sensor
- COD sensor



Features

- The isolated transmission output is adopted, which is less affected by interference
- Adopt isolated RS485 communication technology
- With high and low alarm output function.
- With sound and light alarm function, improve the adaptability of ambient light.

Universal controller

Principle

This universal controller is designed to work in conjunction with our range of digital water quality sensors, enabling continuous monitoring of water quality parameters such as pH, ORP, conductivity, dissolved oxygen, turbidity, sludge concentration, inductive conductivity, residual chlorine, ammonia nitrogen, nitrate nitrogen, COD, and more in solutions. The continuous monitoring data can be remotely transmitted and recorded through a transmission output connected to a recorder. Alternatively, it can be connected to an RS485 interface and communicate with a computer via the Modbus-RTU protocol, allowing the computer to monitor and record the instrument's data.

Parameters	
Display	2.8-inch monochrome LCD screen, resolution 128*64
Dimension	100mm×100mm×150mm
Hole size	92.5mm×92.5mm
Monitoring parameters	pH/ORP/Conductivity/Dissolved oxygen/Turbidity/MLSS/ Inductive conductivity/Free chlorine/NH4-N/NO3-N/COD
Display range	pH: (0~14)pH
	ORP: (-2000~2000)mV
	DO: (0~40)mg/L Saturation: (0~ 200)% Conductivity:(0~600)mS/cm
	Turbidity:(0~4000)NTU
	MLSS:(0~120000)mg/L
	Inductive conductivity: (0~2000)mS/cm
	Free chlorine: (0~5000)ug/L
	NH4-N: (0~1000)mg/L
	NO3-N: (0~1000)mg/L
	COD: (0~1500)mg/L
Current output	Note: The actual measurement range refers to the documentation of the connected sensor (4~20)mA load capacity 500Ω, output accuracy ±0.2%FS
RS485 output	Isolated, Modbus-RTU communication
Alarm	2 channels, capacity AC250V/3A
Distribution output	12V/125mA
Relative humidity	(10 ~ 85)% (no condensation)
Working temperature	(0 ~ 60)°C
Input	AC: (100~240)VAC
	DC: 24VDC(Optional)
Power consumption	≤6W
Cable entries	M12*1.5 suitable gland *1
	M16*1.5 suitable gland *2
Operating temperature	(0 ~ 60)°C
Storage conditions	Temperature:(-15 ~ 65)°C
	Humidity(5 ~ 95)% (no condensation)
	Height:<2000M

Wiring

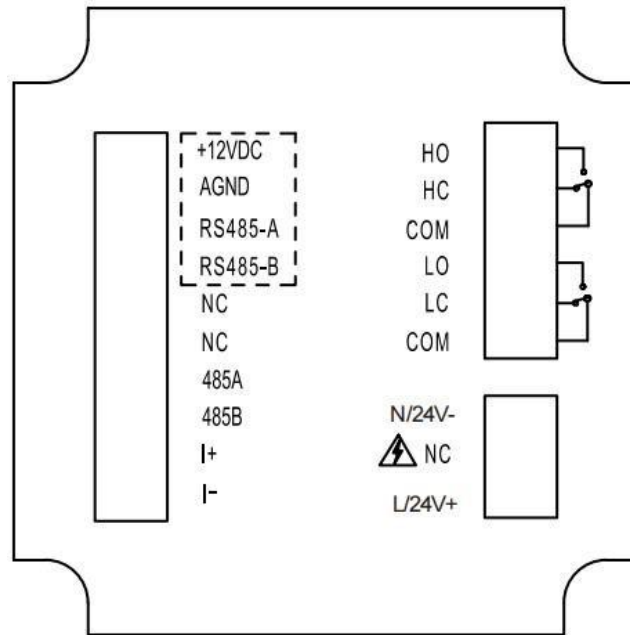

- | | |
|--|--|
| ● +12VDC: 12V positive power supply | ● +12VDC: 12V positive power supply |
| ● AGND: 12V power supply negative pole | ● AGND: 12V power supply negative pole |
| ● RS485-A: sensor RS485 communication terminal A | ● RS485-A: sensor RS485 communication terminal A |
| ● RS485-B: sensor RS485 communication terminal B | ● RS485-B: sensor RS485 communication terminal B |
| ● NC: empty | ● NC: empty |
| ● 485A: RS485 communication terminal A | ● 485A: RS485 communication terminal A |
| ● 485B: RS485 communication terminal B | ● 485B: RS485 communication terminal B |
| ● I+: (4~20)mA output terminal positive | ● I+: (4~20)mA output terminal positive |
| ● I-: (4~20)mA output terminal negative | ● I-: (4~20)mA output terminal negative |
| ● HO: High alarm normally open relay | ● HO: High alarm normally open relay |
| ● HC: High alarm normally closed relay | ● HC: High alarm normally closed relay |

Notice

- To prevent electric shock, please confirm the meter is not powered on before connecting the signal cable.
- To prevent fire, please use double insulated wire.
- Please do not place live products close to the signal terminals, which may cause malfunction.

Installation

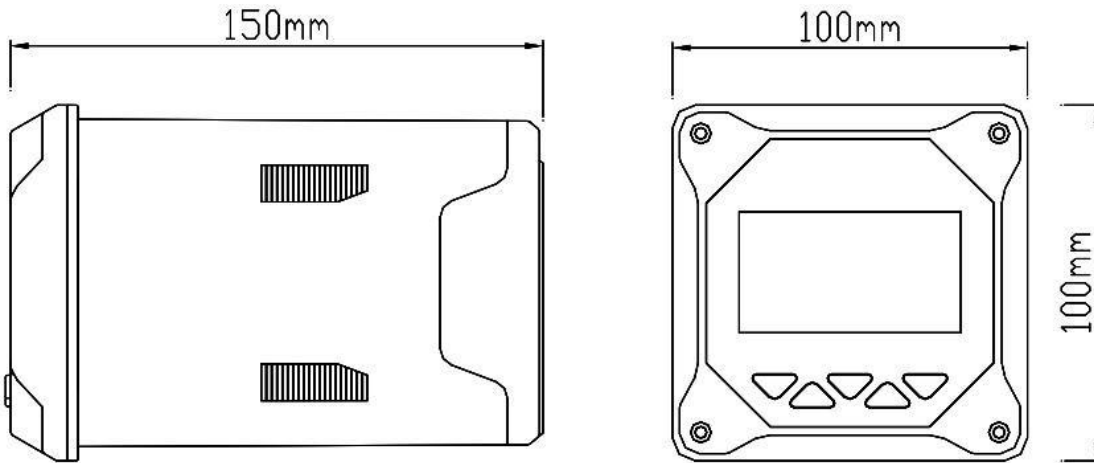

Unit: mm

Weight: 0.65kg.

Installation

■ Installation

4.1 Installation Conditions

Instructions for the installation location and method of this product are provided here. Please read this section carefully during installation.

Relevant Installation Precautions:

- The installation method of this product is panel-mounted.
- Install indoors, away from exposure to rain, wind, and direct sunlight.
- To prevent internal temperature rise of this product, install it in a well-ventilated area.
- During installation, avoid tilting the product left or right, and try to install it horizontally (with a backward tilt of $<30^\circ$ acceptable).

Avoid Installing in the Following Locations:

- Areas where the ambient temperature during operation exceeds 60°C .
- Areas where the ambient humidity during operation exceeds 85%RH.
- Vicinity of electromagnetic sources.
- Areas with strong mechanical vibrations.
- Areas prone to condensation due to significant temperature changes.
- Areas with heavy exposure to oil smoke, steam, moisture, dust, or corrosive gases.

4.2 Controller Installation

Cut a $92.5\text{mm} \times 92.5\text{mm}$ installation hole on the instrument cabinet or mounting panel, with a panel thickness ranging from 1.5mm to 13mm. Insert the instrument directly through the panel of the instrument cabinet, and then secure the butterfly latch accessory provided with the instrument from the rear of the instrument into the fixing slot, as shown in Figure 3.

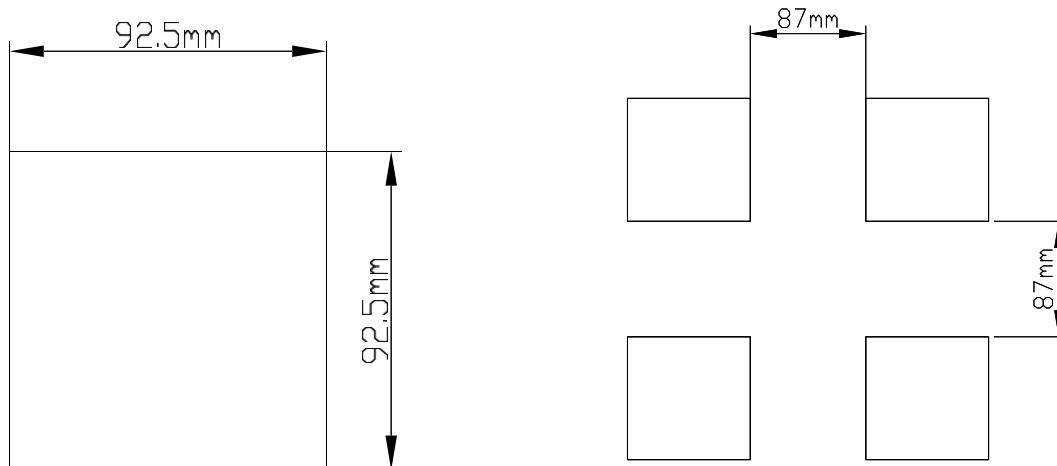

Fig. 2 Dimensions of disk-mounted openings and minimum distance between square holes in instrument cabinets

Insert the meter into the mounting hole then fasten the butterfly clasp as shown in Figure 3:

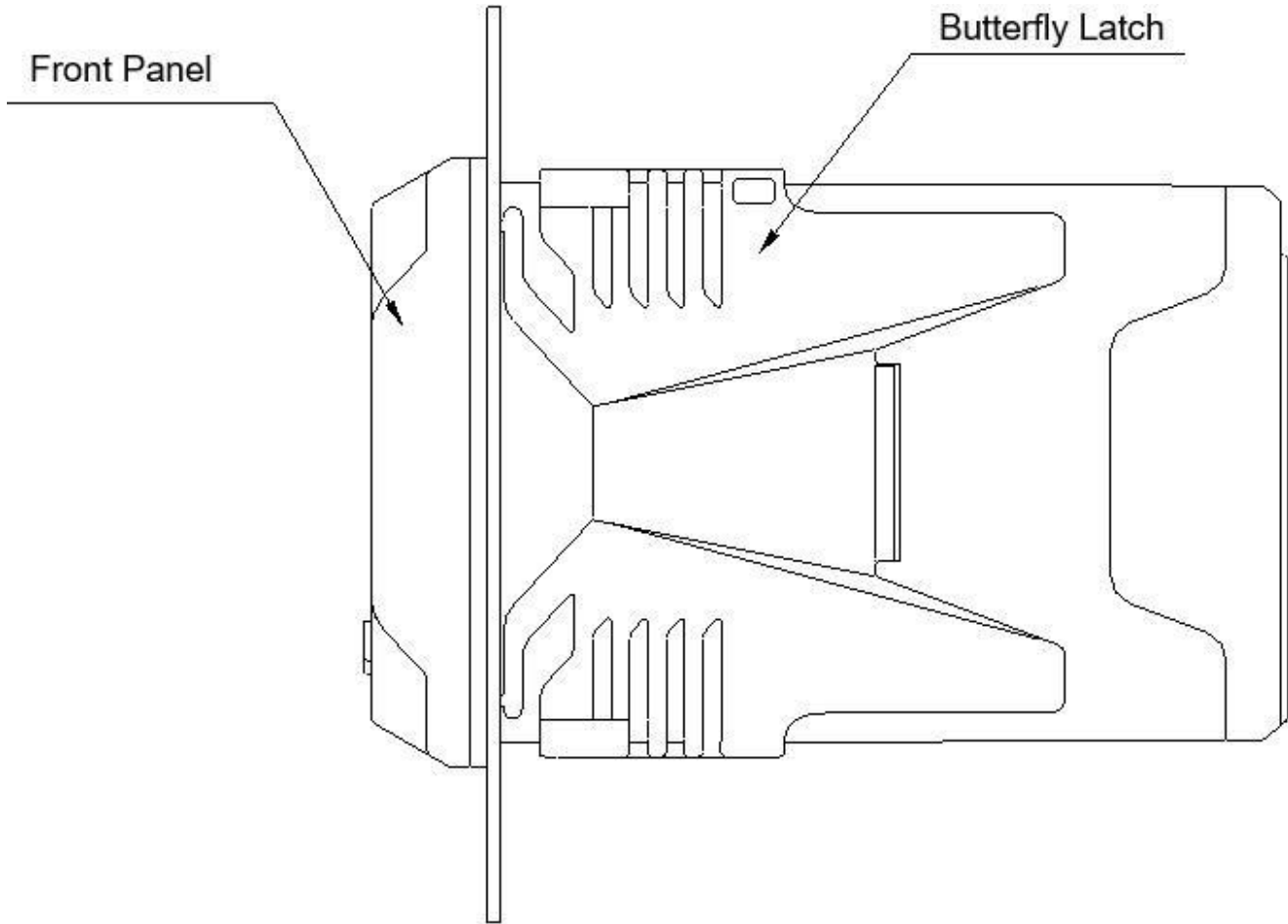
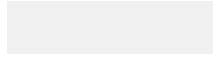

Fig. 3 Schematic diagram of controller disk mounting method

Ordering Code



AI-MA-U2-A-B-4-1-4-E-P1	Description
AI-MA-U2	
Input A	RS485
Output B	-20mA+RS485
Alarm Output 4	2-channel SPDT
Electrical Interface 1	M16×1.5 cable gland×2+M12×1.5 cable gland
Level of Protection 4	IP54
Level of Protection 5	IP65
Power Supply E	220VAC
Power Supply C	24VDC
Accessories P1	304SS Back Panel Mounting Bracket



Arka Instruments LLP

Add: Hyderabad Office: H.no: 08-041/1,
 Plot no 132, N C L Enclave, Kompally,
 Hyderabad, Telangana, India - 500067
 Land Line: +91 40359 00418
 Mobile: +91 81438 12346
 Email: admin@arkainstruments.com
 Website: www.arkainstruments.com